

Application Note for the 4-Pin Package

The 4-Pin package is comprised of a SemiNex submount fiber coupled into a 105um, 0.22NA single core fiber. The output power available is 3.3W to 5.1W depending on wavelength. The standard termination is an SMA-905 connector. This application note is intended to help assist in determining different methods of driving and thermally cooling the package.

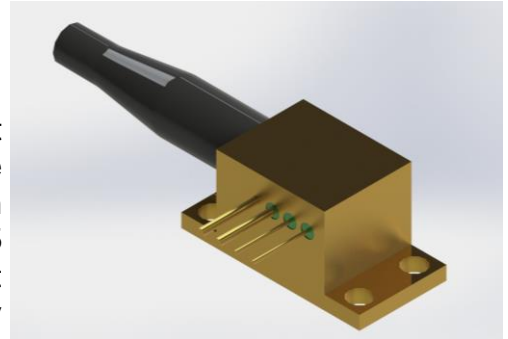

Package Specifications

The 4-Pin package is designed for moderate optical powers transmitted from a single core optical fiber. The housing is a solid body, with electrically isolated feedthroughs and a single exit port for a fiber. The package is designed with four (4) through holes at the corners of the package which are to be used with four (4) 2.5mm screws.

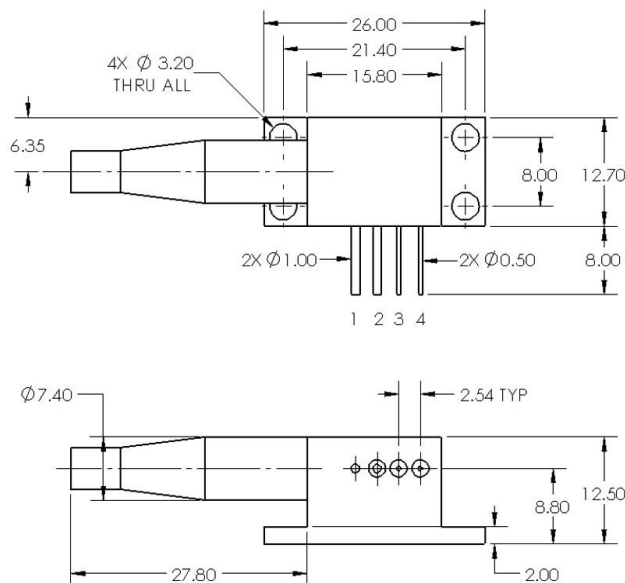

PIN OUT: (FOR REFERENCE ONLY, REFER TO DOCUMENTATION SUBMITTED WITH PRODUCT FOR ACTUAL PIN OUT)

1. LD ANODE (+)
2. LD CATHODE (-)
3. PD (-) or THERMISTOR
4. PD (+) or THERMISTOR

Figure 1. 4-Pin package. Package specifications such as pinouts and options may change. Please contact SemiNex for your specific package and wiring configuration.

All statements, technical information and recommendation related to the product herein are based upon information believed to be reliable or accurate. However, the accuracy or completeness herein is not guaranteed, and no responsibility is assumed for any inaccuracies. The user assumes all risks and liability whatsoever in connection with the use of a product or its application. SemiNex Incorporated reserves the right to change at any time without notice, the design, specification, deduction, fit or form of its described herein, including withdrawal at any time of a product offered for sale herein. Users are encouraged to visit www.seminex.com for the latest data. SemiNex Incorporated makes no representations that the products herein are free from any intellectual property claims of others. Please contact SemiNex Incorporated for more information. © 2013 Copyright SemiNex Incorporated. All rights reserved.



Thermistor (optional)

SemiNex uses an NTC type Thermistor with a constant of 3477 and a resistance of 10,000 Ohms.

Package Attachment

For optimal operation, the package should be attached to a temperature controlled mounting plate, such as a cold plate or TEC. Attaching the laser package requires 4, M2.5 screws. The mounting plate should be tapped with hole patterns to match those in figure 1. For long term use and highly efficient thermal transfer between the package and cooling plate or TEC, a layer of thermal grease or indium foil should be used. Recommended thermal greases are ShinEtsu Micro Si Product X23-7762, ShinEtsu Micro Si Product G751 or Artic Silver 5. Indium foil can be obtained from Indium Corp, part number ribbonin-10101. For short term operation (less than 1 minute), the use of thermal grease or indium can be avoided, but the temperature rise will be larger than with the grease or indium which will result in a decrease in optical power.

Attachment without thermal grease

Wipe the bottom of the package and top of the mounting plate with a clean cloth to remove any particles. Place the package on the mounting plate, align the holes and insert the screws into the package. Tighten the screws by securing one until a resistance is observed and repeat the process with the other screw. Return to the first screw and tighten with a torque wrench. Use caution to prevent over tightening. Do not exceed 5 in-pounds. Repeat with the second screw.

Attachment with Thermal Grease

Wipe the bottom of the package and top of the mounting plate with a clean cloth to remove any particles. Apply a small amount of grease to the bottom of the package. Spread the grease as evenly as possible using the roller or squeegee. Align the bolt holes of the package to the bolt holes in the mounting plate and secure with M3 screws. Tighten the screws as described above. Use caution to prevent over tightening. Do not exceed 5 in-pounds. Remove any excess grease using a towel.

Attachment with Indium Foil

Wipe the bottom of the package and top of the mounting plate with a clean cloth to remove any particles. Cut a small piece of foil approximately 30mm x 30mm and lay it on the mounting plate in the attachment location. Align the bolt holes of the package to the bolt holes in the mounting plate and secure with M3.5 screws. Tighten the screws as described above. Use caution to prevent over tightening. Do not exceed 5 in-pounds.

All statements, technical information and recommendation related to the product herein are based upon information believed to be reliable or accurate. However, the accuracy or completeness herein is not guaranteed, and no responsibility is assumed for any inaccuracies. The user assumes all risks and liability whatsoever in connection with the use of a product or its application. SemiNex Incorporated reserves the right to change at any time without notice, the design, specification, deduction, fit or form of its described herein, including withdrawal at any time of a product offered for sale herein. Users are encouraged to visit www.seminex.com for the latest data. SemiNex Incorporated makes no representations that the products herein are free from any intellectual property claims of others. Please contact SemiNex Incorporated for more information. © 2013 Copyright SemiNex Incorporated. All rights reserved.



4-Pin Package Lead Soldering

Applying direct heat to the body of the 4-Pin package may damage the laser diode. To avoid heating the 4-Pin body, use a soldering iron. A highly recommended soldering iron is the Weller WESD51 Soldering Station (either analog or digital display) equipped with a chisel tip. Chisel tips are thicker at the point of contact and store more heat, reducing the amount of time that heat needs to be applied. Use a flux core solder with a melting point < 200 °C. Turn on the soldering iron and allow it to heat up for 3 to 5 minutes. Wet the soldering sponge with water and ring out any excess. Clean the solder tip with the sponge. Melt a bead of flux core solder onto the tip of the soldering iron. Touch the melted bead of solder to one of the leads of the 4-Pin. Touch flux core solder to lead near soldering iron. Once the flux core solder begins to flow, coat lead with solder. Remove 12mm of insulation from wire that will be attached to lead. Perform same process to coat exposed wire with solder. Melt a bead of flux core solder onto the tip of the soldering. Hold exposed part of wire coated with solder on the lead coated with solder. Touch the melted bead of solder on the wire. Remove soldering iron once the solder of the lead and pin have flowed together.

4-Pin Package Operation

The 4-Pin package has been tested prior to shipment while attached to a 20C cold plate using indium foil. A typical LIV at various test temperatures appears in figure 2.

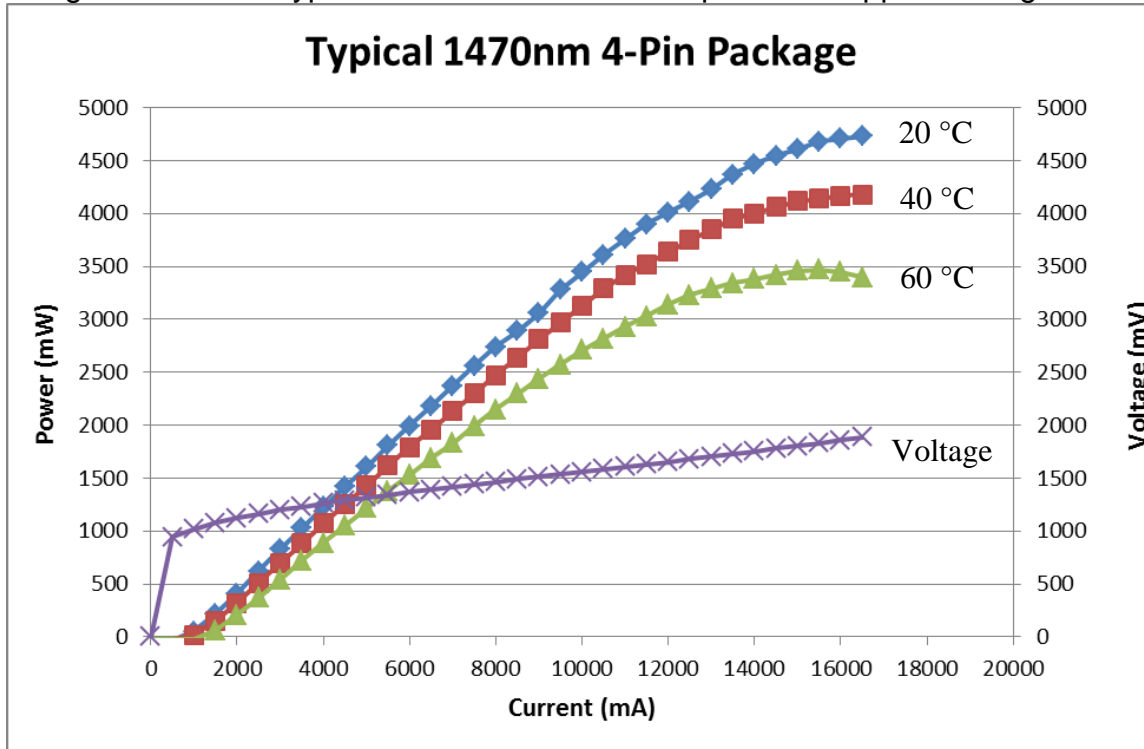

All statements, technical information and recommendation related to the product herein are based upon information believed to be reliable or accurate. However, the accuracy or completeness herein is not guaranteed, and no responsibility is assumed for any inaccuracies. The user assumes all risks and liability whatsoever in connection with the use of a product or its application. SemiNex Incorporated reserves the right to change at any time without notice, the design, specification, deduction, fit or form of its described herein, including withdrawal at any time of a product offered for sale herein. Users are encouraged to visit www.seminex.com for the latest data. SemiNex Incorporated makes no representations that the products herein are free from any intellectual property claims of others. Please contact SemiNex Incorporated for more information. © 2013 Copyright SemiNex Incorporated. All rights reserved.



Figure 2. Typical LIV of a 1470nm 4-Pin package at various base temperatures.

As seen in figure 2, proper heat sinking and maintaining of the base temperature is critical for achieving peak optical power performance. A recommended safe operating range is between 500mA and 90% of peak power. Peak power and slope will change with the mounting plate, plate and ambient temperatures.

4-Pin Package Laser Driver Requirements

When selecting the power supply, care should be taken to ensure electrical overstressing of the package can not occur. Overstressing occurs when a package is subjected to voltage or current levels beyond its' surge-absorbing capacity. Some recommended guidelines for preventing overstress of the package are:

- Overcurrent protection should be set to the current level at 100% of peak power.
- Use transient suppression for power supplies.
- Use over-voltage or voltage limiting protection
- Confirm packages are connected using the proper pin configurations.
- Ensure all wire used to connect to the package are of the proper gauge to sufficiently carry the desired drive current at the operational ambient temperature.

All statements, technical information and recommendation related to the product herein are based upon information believed to be reliable or accurate. However, the accuracy or completeness herein is not guaranteed, and no responsibility is assumed for any inaccuracies. The user assumes all risks and liability whatsoever in connection with the use of a product or its application. SemiNex Incorporated reserves the right to change at any time without notice, the design, specification, deduction, fit or form of its described herein, including withdrawal at any time of a product offered for sale herein. Users are encouraged to visit www.seminex.com for the latest data. SemiNex Incorporated makes no representations that the products herein are free from any intellectual property claims of others. Please contact SemiNex Incorporated for more information. © 2013 Copyright SemiNex Incorporated. All rights reserved.