

High Power Multi-Mode SemiNex Lasers
 6 Watts of Continuous Operation Power
 1470, 1532, or 1550 nm Wavelength
 High Heat Load - Window Package

SemiNex delivers the highest available CW power at infrared wavelengths. SemiNex will optimize the design of its laser chips to meet customers' optical and electrical performance specifications. Diodes are mounted and tested to meet custom applications. Typical results and packaging options are shown below. Contact SemiNex for additional details or to discuss your application.

Key Features

- High output power
- High dynamic power range
- High efficiency
- Custom packaging

Applications

- Medical laser equipment
- LIDAR
- Free Space Optical Communication
- DPSS pump lasers
- Military / Aerospace

	Symbol	Typical	Units
Optical			
Output power (CW)	P_o	5 or 6	watts
Center Wavelength Range	λ_c	1470, 1532, or 1550	nm
Emitter Width	W	95	μm
Emitter Height	H	1	μm
Spectral Width	$\Delta\lambda$	10	nm 3dB
Slope Efficiency	η_o	0.5	W/A
Fast Axis Divergence	θ_{perp}	26	deg FWHM
Slow Axis Divergence	θ_{parallel}	8	deg FWHM
Wavelength Temp. Coeff.	λ_{coef}	0.7	nm/C

Electrical			
Power conversion Efficiency	η	0.5	W/A
Threshold Current	I_{th}	0.45	A
Operating Current	I_{op}	10	A
Operating Voltage	V_{op}	2.0	V
Series Resistance	R_s	0.05	ohm

Typical CW LIV Optical Power Chart

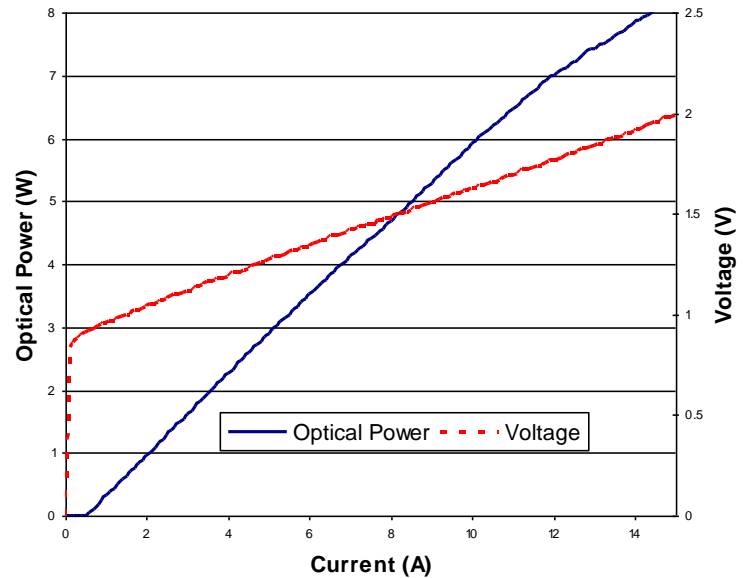

SemiNex Corporation
 100 Corporate Place
 Suite 401
 Peabody, MA 01960
 Phone: 978-278-3550
 Email: info@seminex.com
 Web site: www.seminex.com

All statements, technical information and recommendation related to the product herein are based upon information believed to be reliable or accurate. However, the accuracy or completeness hereof is not guaranteed, and no responsibility is assumed for any inaccuracies. The user assumes all risks and liability whatsoever in connection with the use of a product or its application. SemiNex Incorporated reserves the right to change at any time without notice, the design, specification, deduction, fit or form of its described herein, including withdrawal at any time of a product offered for sale herein. SemiNex Incorporated makes no representations that the products herein are free from any intellectual property claims of others. Please contact SemiNex Incorporated for more information. © 2009 Copyright SemiNex Incorporated. All rights reserved.



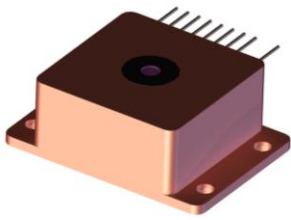

	Symbol	HHL-1470-6-95	HHL-1532-6-95	HHL-1550-6-95	Units
Optical					
Output power (CW)	P_o	6	5	5	watts
Center Wavelength	λ_c	1470	1532	1550	nm
Emitter Width	W	95	95	95	μm
Emitter Height	H	1	1	1	μm
Spectral Width	$\Delta\lambda$	10	10	10	nm 3dB
Slope Efficiency	η_o	0.5	0.5	0.5	W/A
Fast Axis Divergence	θ_{perp}	26-30	26-30	26-30	deg FWHM
Slow Axis Divergence	θ_{parallel}	4- 8	4 - 8	4- 8	deg FWHM
Electrical					
Power conversion Efficiency	η	0.5	0.5	0.5	W/A
Threshold Current	I_{th}	0.45	0.45	0.45	A
Operating Current	I_{op}	10	10	10	A
Operating Voltage	V_{op}	2.0	2.0	2.0	V
Series Resistance	R_s	0.05	0.05	0.05	ohm
Lead Soldering Temperature	$^{\circ}\text{C}$	250	250	250	$^{\circ}\text{C}$
TEC (Optional)					
TEC Voltage	V	8.6	8.6	8.6	V
TEC Current	A	3.8	3.8	3.8	A
Thermistor (Optional)					
Resistance	R	10 +/- 5% @ 25 $^{\circ}\text{C}$	10 +/- 5% @ 25 $^{\circ}\text{C}$	10 +/- 5% @ 25 $^{\circ}\text{C}$	K ohm
Thermistor Constant	β	3477 +/- 3%	3477 +/- 3%	3477 +/- 3%	β

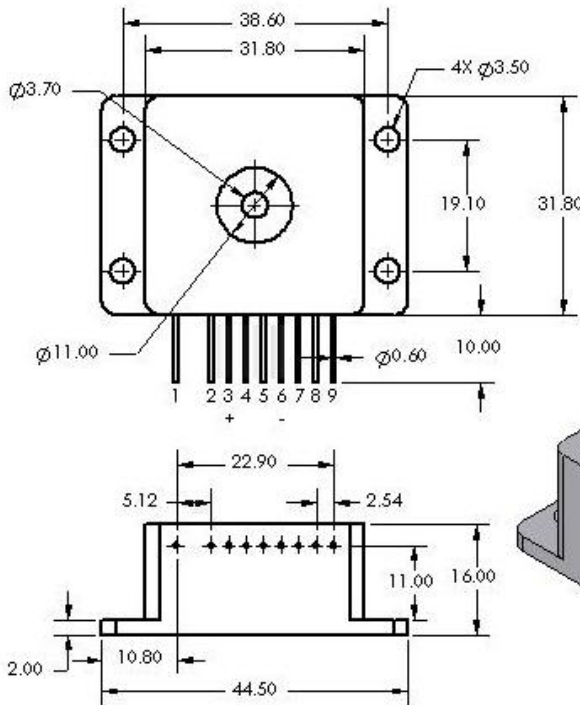

PIN CALLOUT: (FOR REFERENCE ONLY, REFER TO DOCUMENTATION SUBMITTED WITH PRODUCT FOR ACTUAL PIN CALLOUTS)

1. TEC (-)(OPTIONAL)
2. CASE
3. LASER ANODE (+)
4. THERMISTOR (OPTIONAL)
5. THERMISTOR (OPTIONAL)
6. LASER CATHODE (-)
7. PD ANODE (OPTIONAL)
8. PD CATHODE (OPTIONAL)
9. TEC (+)(OPTIONAL)

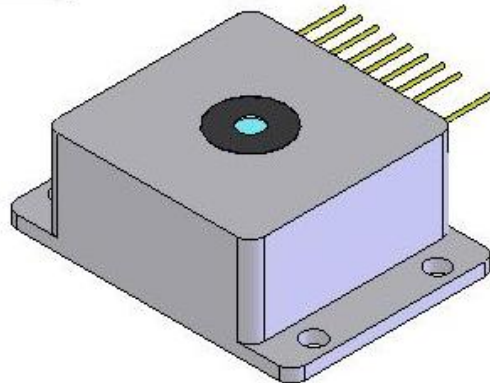

NOTE: Dimensions are in mm

All statements, technical information and recommendation related to the product herein are based upon information believed to be reliable or accurate. However, the accuracy or completeness hereof is not guaranteed, and no responsibility is assumed for any inaccuracies. The user assumes all risks and liability whatsoever in connection with the use of a product or its application. SemiNex Incorporated reserves the right to change at any time without notice, the design, specification, deduction, fit or form of its described herein, including withdrawal at any time of a product offered for sale herein. SemiNex Incorporated makes no representations that the products herein are free from any intellectual property claims of others. Please contact SemiNex Incorporated for more information. © 2009 Copyright SemiNex Incorporated. All rights reserved.

SemiNex Corporation
 100 Corporate Place
 Suite 401
 Peabody, MA 01960
 Phone: 978-278-3550
 Email: info@seminex.com
 Web site: www.seminex.com

